

Goods  
delivery  
vehicles  
only



BEWARE  
FORKLIFT  
OPERATING  
IN THIS AREA

# Freight Hoist Scissor Lift



**McGrath Industries multistage scissor lifts are ideal for transferring freight between floors in low rise two or three level buildings such as warehouses, retail complexes and factories.**

Compared to a goods-passenger elevator, a “freight only” multistage scissor lift is a very economical alternative. And cost savings extend into the building construction itself. A scissor lift is a self supporting structure, carrying the load directly back to the ground. There is no need to design and construct the building to support the hoist and payload.

A Freight Hoist Scissor Lift is enclosed within a hoist shaft similar to an elevator. In some Ground Level to Mezzanine installations and loading dock applications, the hoist shaft maybe a simple fenced enclosure.

Doors may be manually or power operated, electrically activated door interlocks will only allow access into the hoist shaft when the scissor lift’s Cargo Deck is at that level.

Controls on each landing typically include Call and Send buttons and level indicators. An intercom can be added to assist staff at each level coordinate their activities.





## PIT MOUNTED IN BUILDING LIFT SHAFT

A Freight Hoist Scissor Lift installation can also be dual purpose, acting as an Elevating Dock for delivery truck loading operations.

The hoist may operate between Ground Level, truck deck height and the First or Second Level of the building. This allows freight to be transferred directly between a delivery vehicle and any level of the building using a single hoist movement that occupies minimal building area.

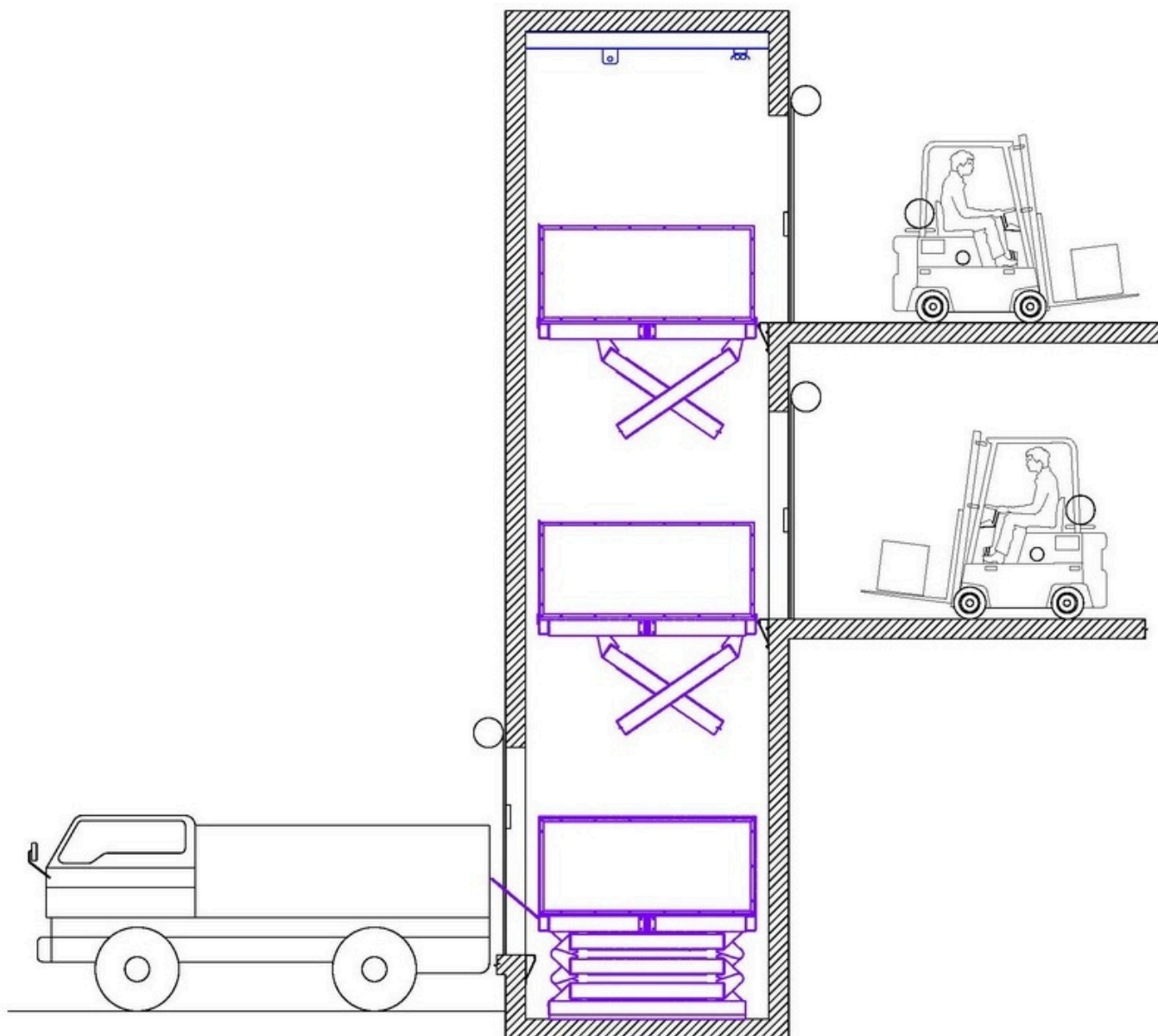

Freight Hoist Scissor Lifts can be configured with up to four scissor leg sets stacked vertically. The legs sets open and close simultaneously to move the freight smoothly between levels. The hoist mechanism is powered by electro-hydraulic action. The hydraulic power plant is usually located adjacent to the lift shaft and may be enclosed in it's own ventilated machine room to minimise noise during loperation Popular models are listed on the table below. McGrath Industries can also design and manufacture a Freight Hoist Scissor Lift to meet your specific load capacity, deck size and travel distance requirements.

## POPULAR MODELS

Product Code	Maximum Load Capacity	Deck Area Length x Width	Maximum Range of Travel	Minimum Pit Depth	Height Overall
0.5-1.1/0.7-1.3	500kg	1.1m x 0.7m	1.3m	550mm	1850mm
0.5-1.6/1.6-3.0	500kg	1.6m x 1.6m	3.0m	750mm	3750mm
1.0-2.0/1.6-2.5	1.0 tonne	2.0m x 1.6m	2.5m	620mm	3120mm
1.5-2.3/1.4-2.6	1.5 tonnes	2.3m x 1.4m	2.6m	600mm	3200mm
1.5-2.2/1.5-3.0	1.5 tonnes	2.2m x 1.5m	3.0m	1050mm	4050mm
1.5-3.3/1.6-4.0	1.5 tonnes	3.3m x 1.6m	4.0m	1000mm	5000mm
1.5-2.0/1.5-5.5	1.5 tonnes	2.0m x 1.5m	5.5m	1250mm	6750mm

## GENERAL SPECIFICATION

### Lifting Speed Range:

- 2.0 - 6.0 metres per minute to suit travel distance.

### Lowering Speed:

- Generally matched to Lifting Speed.

### Standard Cargo Deck Size and Type:

- Smooth reinforced flat steel surface with anti skid grit finish.

### Standard Features:

- Maintenance Props are fitted to allow service staff to work safely under the raised hoist.
- Inspection Hatch provides service staff access through the Cargo Deck.

### Standard Electrical Supply:

- 3 phase + Earth 50 Hz. Electrical supply should be to a point adjacent to the hoist hydraulic power plant position, (by others). Supply cable to be unterminated.

### Standard Paint Finish:

- Industrial Grey with Safety Yellow Load Flips if included.

### Optional Features:

- Load Lips can be added to the interfacing edges of the Cargo Deck for truck loading operations or where the gap at the door sill varies due to lift shaft discrepancies. Load Lips may be manually operated or powered.
- Ride-on Capability allows a trained operator to ride on the platform with the load between floors. Includes onboard controls plus additional safety features such as light curtains.
- Guard Walls attached to non-interfacing edges of the Cargo Deck help contain the freight within the deck area and protect lift shaft walls from impact damage.



**AUCKLAND**

5-9 Cartwright Road, Glen Eden,  
Auckland, New Zealand  
Phone: +64 (0)9 818-6036  
enquiries@mcgrath.co.nz

**SYDNEY**

PO Box 578, Mascot, NSW 2020,  
Australia  
Phone: +61 (0)2 8339-0123  
enquiries@mcgrath-industries.com

MADE IN NEW ZEALAND  
[www.mcgrath.co.nz](http://www.mcgrath.co.nz)

